

THROUGH the process of habituation, the eye rotational response of the vestibulo-ocular reflex (VOR) can be reduced by prolonged exposure to a head rotational stimulus. In previous work, the goldfish VOR habituated at a single, low frequency (≤ 0.1 Hz) showed frequency specific effects at and near that frequency, and could be dishabituated when combined with a higher frequency rotation. Here we show that the goldfish VOR exposed to prolonged rotation at two frequencies in combination will still produce habituation at low frequency, and can exhibit effects specific to both frequencies. The VOR at a low frequency can be dishabituated if the combined component is switched to a different frequency. These results demonstrate dual-frequency and context specificity of VOR habituation. *NeuroReport* 10:1729–1734 © 1999 Lippincott Williams & Wilkins.

Key words: Dishabituation; Goldfish; Habituation; Learning; Linear-systems model; Plasticity; VOR

Dual-frequency habituation and dishabituation of the goldfish vestibulo-ocular reflex

Ernst R. Dow^{1,2,4} and Thomas J. Anastasio^{1,3,CA}

¹Center for Biophysics and Computational Biology, ³Department of Molecular and Integrative Physiology and ²Beckman Institute, University of Illinois at Urbana/Champaign, 405 North Mathews Ave., Urbana, IL 61801, USA

⁴Present Address: IT, Research Technologies and Discovery (Bioinformatics), Lilly Research Laboratories, Lilly Corporate Center, Indianapolis, IN 46285, USA

CA,⁴Corresponding Author and Address

Introduction

The vestibulo-ocular reflex (VOR) helps stabilize the visual image on the retina by producing eye rotations that are directed opposite to head rotations. The VOR is mediated by neurons in the vestibular nuclei that receive sensory input from semicircular canal afferent neurons and send commands to eye muscle motoneurons. The semicircular canal receptors act as integrating head rotational accelerometers [1], and the activities of semicircular canal afferents appear as high-pass filtered versions of head velocity [2]. In naive animals (those never before exposed to experimentally produced rotation), VOR eye velocity bears approximately the same relationship to head velocity as the output bears to the input of a high-pass filter (HPF) [1,3–7].

The VOR is highly plastic, and this plasticity appears to involve the cerebellum [7–14]. VOR habituation is a form of VOR plasticity in which the VOR response to a rotational stimulus can be reduced by prolonged exposure to that stimulus. Habituation occurs only for rotation in the dark. Prolonged sinusoidal rotation in the dark at single

frequencies below 0.1 Hz can reduce the VOR response at those frequencies in many species (for review see [15]).

In previous work we have shown that the VOR habituates faster and more completely in goldfish than in other vertebrates studied [6,16–18] and it is frequency specific. Habituation following prolonged rotation at a single frequency results in a decrease in VOR gain (eye velocity amplitude/head velocity amplitude) primarily at the frequency of habituation, and an increase and decrease in phase (eye velocity phase–inverted head velocity phase) at nearby frequencies above and below the frequency of habituation, respectively [7]. We have also shown that the VOR habituated at a single, lower frequency can be temporarily dishabituated when rotation at that frequency is combined with rotation at a higher frequency [13]. Neither habituation nor dishabituation of the VOR occurs in cerebelectomized goldfish [13,14].

These findings raise several questions. In this study we answer three of these experimentally using stimuli consisting of two frequencies of rotation in combination. First, we show that prolonged rotation at two different, lower frequencies in the dark can

produce frequency-specific habituation effects at each frequency. Secondly, we show that prolonged rotation in the dark at a lower and a higher frequency in combination will still produce habituation at the lower frequency. Finally, we show that the VOR habituated at a lower frequency, by prolonged rotation in the dark at that frequency in combination with a second component frequency, can be dishabituated when the second component is switched to a different frequency. These findings show that VOR habituation is more frequency- and context-specific than had been appreciated previously, and indicate that the cerebellum is capable of intricate control over the VOR.

Materials and Methods

We studied habituation and dishabituation of the VOR to stimuli consisting of two frequencies of sinusoidal rotation presented simultaneously (i.e. superimposed). The experimental subjects were 25 intact, experimentally naive, comet goldfish (*Carassius auratus*) that were 10–15 cm in length. Each goldfish was restrained horizontally underwater in a cylindrical tank with its head at the center. Both the tank and the experimental chamber were covered with opaque shrouds. Eye movements were measured in the dark using the magnetic search coil technique [19,20] (see [13] for technical details).

The tank was centered on the vertical axis of rotation of a horizontal rotating platform. All single- and dual-frequency stimuli had peak rotational velocities of 60 and 120 deg/s, respectively. Eye rotational position and rotator (i.e. head) velocity signals were digitized for analysis.

Eye position data were digitally differentiated to compute eye velocity. Fast phases were removed automatically by computer algorithm and one or two least-square sinusoids were fit to the data. Non-linear portions of the slow-phase eye velocity data were often observed and were removed by eye before fitting least-square sinusoids (Fig. 1) [13,14,21]. The sinusoids best-fit to the sinusoidal portions of the data provided the best linear estimates of slow-phase eye velocity amplitude and phase. Least-squares sinusoids were also fit to the head velocity data. VOR gain and phase were computed from the parameters of the best-fit sinusoids.

The focal point for the analysis was habituation at the lowest frequency examined: 0.01 Hz. Each naive goldfish was first rotated for 1 h at 0.01 Hz paired with one of the following habituating component frequencies: 0.03, 0.05, 0.1, 0.3, 0.5 or 1.0 Hz. The frequency response was then measured by rotating each goldfish in order at the following single fre-

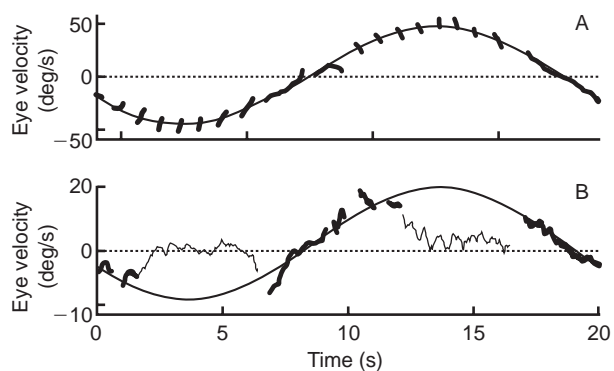

FIG. 1. Least squares sinusoid fit to estimate the amplitude and phase of goldfish VOR slow-phase eye velocity during single frequency rotation at 0.05 Hz. Fast phases have been removed automatically by computer algorithm and are not shown. (A) Single frequency response following 1 h of combined rotation at 0.01 Hz and 0.5 Hz. (B) Single frequency response following 1 h of combined rotation at 0.01 Hz and 0.03 Hz. Least-squares sinusoids (smooth curves) are fit to the sinusoidal portions of the slow-phase eye velocity records (darker data points). Lighter data points show 'notches' where the response is briefly attenuated but then recovers during the same half-cycle of rotation. The non-sinusoidal notches were removed by eye prior to fitting the least-squares sinusoid.

quencies: 1.0, 0.5, 0.3, 0.1, 0.05, 0.03 and 0.01 Hz. To minimize habituation effects [7,14,21], the duration of the single-frequency rotations were kept brief and ranged from 30 s (1.0 Hz) to 130 s (0.01 Hz). Finally, dishabituation at 0.01 Hz due to superposition was tested by rotating each goldfish for 130 s at 0.01 Hz in combination with each one of the following test component frequencies: 1.0, 0.3 and 0.05 Hz.

Due to the presence of some extreme values, the median rather than the mean was used as a measure of central tendency, and the first and third quartiles provided the associated measures of variability. Significance was tested non-parametrically with a two-tail Mann-Whitney U-test. Data were analyzed and modeled using MATLAB (The Mathworks, Inc.).

Results and Discussion

We examined the response of the goldfish VOR to sinusoidal rotations presented alone, and in combination over prolonged habituation periods or during brief test periods. Prolonged rotation produced VOR habituation at lower frequencies (see below). During and following habituation, the response of the VOR was not always sinusoidal. Non-linear responses associated with habituation have been observed previously in goldfish [14,21]. We observed a type of non-linear response that has not been reported previously. Primarily at low frequencies (i.e. 0.03 and 0.05 Hz) there can be an abrupt decrease in response amplitude at a point in a response half-cycle before which peak eye velocity has been reached, followed by an abrupt restoration after peak eye velocity would have been reached (Fig. 1). Abrupt decreases in response have been observed

previously [14], but these usually occurred at peak eye velocity and did not rebound during the same half-cycle of rotation.

Habituation and dishabituation to combined frequency rotation: Previous research has shown that the goldfish VOR strongly habituates to prolonged rotation at low single frequencies (<0.1 Hz) [13,21]. It also showed that the VOR habituated at a single low frequency could be dishabituated at that frequency when it was combined with a higher frequency rotation [13]. These results suggested that the habituated state, once established, was dependent in some way upon the spectral content of the rotational stimulus. It raised the question of whether or not habituation could still become established at a low frequency were prolonged rotation at that frequency to be combined with rotation at a higher frequency.

We studied VOR habituation following prolonged rotation at two frequencies in combination. These stimuli lasted for 1 h and consisted of rotation at 0.01 Hz combined with rotation at another habituating component frequency chosen from the range 0.03–1.0 Hz. We examined the habituated VOR in various ways following prolonged, combined frequency rotation. These included measuring the response of the habituated VOR at single frequencies in the range from 0.01 to 1.0 Hz (see below). We found that single frequency gain at 0.01 Hz decreased significantly following prolonged rotation at 0.01 Hz in combination with each of the habituating component frequencies employed (see also below). However, single frequency gain at 0.01 Hz was even lower following single frequency habituation (0.020) [14,21] than following any combined frequency habituation (see Fig. 3 gain values at 0.01 Hz).

Gain at 0.01 Hz was measured while 0.01 Hz and the other habituating component frequency were superimposed both before (naive) and after (habituated) 1 h of combined rotation. For all of the habituating component frequencies employed, combined frequency gain at 0.01 Hz decreased substantially following combined frequency habituation (Fig. 2, naive *vs* habituated). The decrease in combined frequency gain at 0.01 Hz was significant when compared with naive in combination with the following habituating component frequencies: 0.03 Hz ($p < 0.01$), 0.1 Hz ($p < 0.05$), 0.3 Hz ($p < 0.01$), 0.5 Hz ($p < 0.05$) and 1.0 Hz ($p < 0.01$). Substantial decreases compared with naive were also observed in all three cases in which 0.01 Hz gain was retested in combination with the habituating component frequency following single frequency rotations in the range from 0.01 to 1.0 Hz to determine the frequency response (see below). Re-

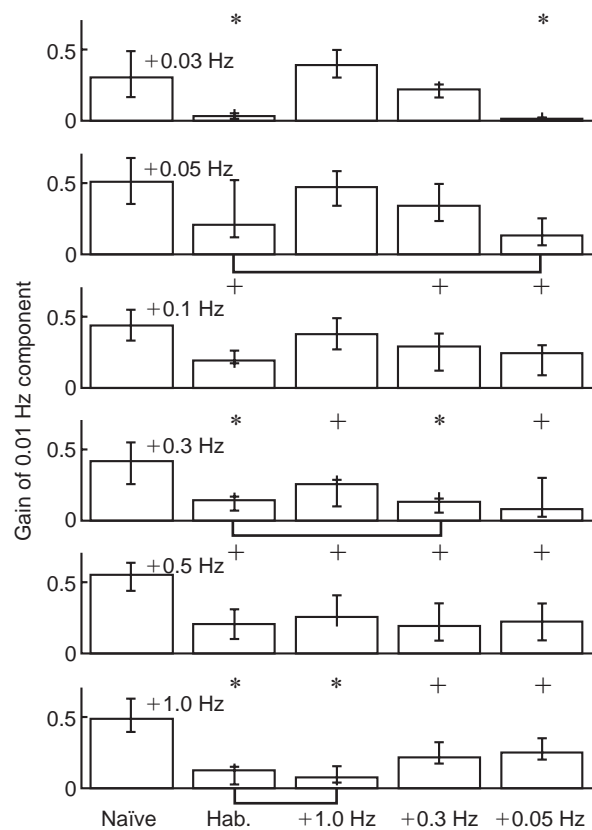

FIG. 2. VOR gain at 0.01 Hz before and after 1 h of rotation at 0.01 Hz combined with rotation at the habituating component frequency shown in the inset of each panel. Combined frequency gain at 0.01 Hz was measured at the beginning (naive) and end (hab.) of the hour. It was also measured at the end of the hour when 0.01 Hz was combined with three different test component frequencies: 1.0, 0.3 and 0.05 Hz. Bars indicate the median ($n = 5$ for +0.03, +0.01, +0.3 and +1.0; $n = 6$ for +0.05, and $n = 3$ for +0.5) and the error bars indicate the first and third quartiles. When the gain was measured twice at the same frequency (B,D,F), a heavy line connects the bars. Data that differed significantly from the naive values are indicated: * $p < 0.01$, + $p < 0.05$.

tested gain at 0.01 Hz was significantly different from naive when combined with the following habituation/test component frequencies: 0.05 ($p < 0.05$), 0.3 Hz ($p < 0.01$) and 1.0 Hz ($p < 0.05$). These results show that VOR gain at 0.01 Hz can habituate even when prolonged 0.01 Hz rotation is combined with rotation at another habituating component frequency ranging from 0.03 to 1.0 Hz.

Previous work has shown that the VOR habituated by prolonged, single frequency rotation at 0.01 Hz could be temporarily dishabituated at that frequency by superimposing rotation at 0.01 Hz and a higher frequency component [13]. We investigated the possibility that the VOR habituated at 0.01 Hz by prolonged, combined rotation with another, habituating component frequency could then be dishabituated by superimposing 0.01 Hz and a test component frequency that was different from the habituating component frequency. Following habituation at 0.01 Hz in combination with habituating

components of 0.03, 0.05 or 0.1 Hz, the VOR response to 0.01 Hz rotation could then become dishabituated when it was paired with test component frequencies of either 1.0 or 0.3 Hz. The increase in gain at the 0.01 Hz component when the second component was switched from habituating to test was significant when the habituating component was 0.03 Hz and the test component was 0.3 or 1.0 Hz ($p < 0.01$), and when the habituating component was 0.1 Hz and the test component was 1.0 Hz ($p < 0.05$). These results show that VOR gain at 0.01 Hz, following prolonged rotation at 0.01 Hz and another low frequency in combination, can be dishabituated by then pairing the 0.01 Hz rotation with a higher frequency component.

When the habituating component was 1.0 Hz, the response at 0.01 Hz was slightly dishabituated when paired with test components at lower frequencies. This difference was significant for test components of 0.3 and 0.05 Hz ($p < 0.01$). These results show that VOR gain at 0.01 Hz, following prolonged rotation at 0.01 Hz and a higher frequency in combination, can be dishabituated by then pairing the 0.01 Hz rotation with a lower frequency component.

Taken together, the results show that the goldfish VOR can be habituated at a low frequency even if prolonged rotation at that frequency is combined

with a higher frequency component that can exceed the frequency of the low frequency component by up to two orders of magnitude. They further show that habituation at the low frequency can be temporarily reversed by either increasing or decreasing the frequency of the higher frequency component.

Frequency response: The frequency response of the goldfish VOR can be altered by exposure to 1 h of single frequency rotation at frequencies < 0.1 Hz [7]. Here we studied the VOR frequency response following habituation at two frequencies in combination. Goldfish were first rotated for 1 h at 0.01 Hz in combination with a habituating component frequency. The frequency response was then determined by measuring VOR gain and phase at single frequencies in the range 0.01–1.0 Hz.

Decreases in gain were observed at and near 0.01 Hz and the habituating component frequency when the latter took values of 0.03 and 0.05 Hz (Fig. 3A,C). Some of these decreases were significant when compared with single frequency gains measured in naive goldfish [7]: habituating component at 0.03 Hz, significant gain decrease at 0.01 ($p < 0.01$), 0.03 ($p < 0.01$) and 0.05 Hz ($p < 0.001$); habituating component at 0.05 Hz, significant gain decrease at 0.05 ($p < 0.05$) and 0.1 Hz ($p < 0.05$).

Phase lead (positive phase) was near naive values

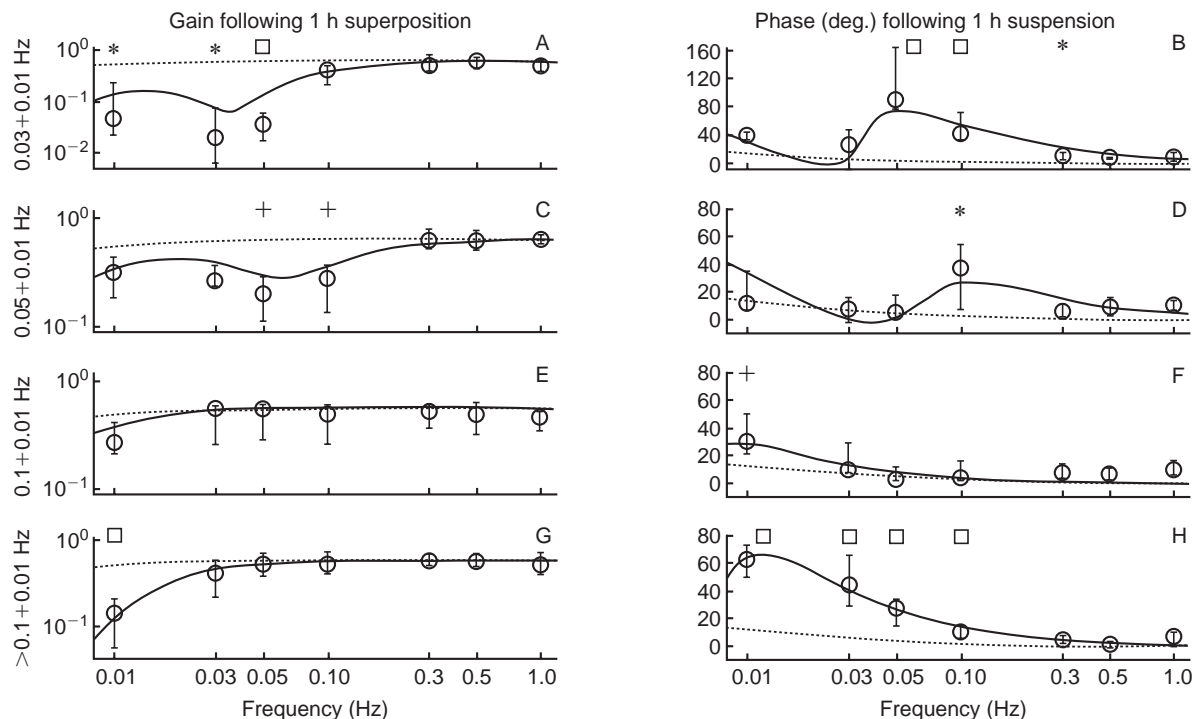

FIG. 3. VOR frequency response to single frequency rotations following 1 h of rotation at 0.01 Hz combined with rotation at another habituating component frequency. The single frequencies tested were: 0.01, 0.03, 0.05, 0.1, 0.3, 0.5 and 1.0 Hz. The habituating component frequencies are listed on the ordinate. In (G) and (H) frequency response data were pooled for combined frequency habituations of 0.3, 0.5 and 1.0 Hz. Each data point indicates the median ($n = 5$ for A-B and E-F, $n = 6$ for C-D, and $n = 14$ for G-H) and error bars indicate the first and third quartile. Data that differed significantly from previously published naive values for goldfish are indicated: □ $p < 0.001$, * $p < 0.01$, + $p < 0.05$. The previously determined fit to naive data is shown as a dashed line, and the fit of the HPF-2BPF model to the habituated data is shown as a solid line.

at the habituating component frequencies when the latter were 0.03 and 0.05 Hz, but was markedly increased at nearby higher frequencies (Fig. 3B,D). Some of these differences were significant when compared with single frequency phase leads measured in naive goldfish: habituating component at 0.03 Hz, significant phase-lead increase at 0.05 ($p < 0.001$), 0.1 ($p < 0.001$) and 0.3 Hz ($p < 0.01$); habituating component at 0.05 Hz, significant phase-lead increase at 0.1 Hz ($p < 0.01$). Phase lead increased slightly at 0.01 Hz but this was not significant ($p > 0.05$).

When the habituating component was 0.1 Hz there was a slight decrease in gain at 0.01 Hz but this was not significant ($p > 0.05$). Phase lead increased slightly at the lower frequencies and was only significant at 0.01 Hz ($p < 0.01$).

VOR frequency responses were very similar when measured following prolonged rotations at 0.01 Hz and one of the following three habituating components: 0.3, 0.5 and 1.0 Hz. A frequency-by-frequency comparison revealed that none of the gain data were statistically different from the others ($p > 0.05$), though there was a small variation in high frequency phase (0.5 and 1.0 Hz, $p < 0.05$). These three frequency responses were pooled due to their similarity. With habituating components of 0.3, 0.5 or 1.0 Hz, single frequency gain decreased substantially at 0.01 Hz and slightly at 0.03 Hz. This decrease was significant only at 0.01 Hz ($p < 0.001$). Phase lead increased substantially between 0.01 and 0.1 Hz. This increase in phase lead was significant at 0.01, 0.03, 0.05 and 0.1 Hz ($p < 0.001$).

Model: The data reported here clearly show changes in the VOR frequency response following 1 h of rotation at 0.01 Hz in combination with each of the habituating components that were employed. The details of these changes were specific to the frequency of the habituating component. Previous research demonstrated changes in the frequency response of the goldfish VOR following 1 h of sinusoidal rotation at single habituating frequencies ≤ 0.1 Hz [7]. Following habituation at a single, lower frequency, frequency response gain decreased at and near that frequency with an increase and decrease in phase lead at nearby higher and lower frequencies, respectively. In previous work we have used a fractional order high-pass filter (HPF) to fit VOR data from naive goldfish [6,7]. To fit the single frequency habituation data a band-pass filter (BPF), centered at or near the single habituating frequency, was subtracted from the HPF model of the VOR (HPF-BPF model) [7]. This model produced the dip in gain centered on the single habituating frequency,

and the increase and decrease in phase lead at nearby higher and lower frequencies, respectively.

It is not possible to fit all of the frequency response data of goldfish habituated at combinations of two frequencies with the same HPF-BPF model. For lower frequency habituating components (0.03 and 0.05 Hz) there is a phase lead at nearby higher frequencies but there is no decrease in phase lead at nearby lower frequencies. The decrease in gain affected a wider frequency range than observed for single frequency habituation, and showed shallow dips near 0.01 Hz and the habituating component frequency. In order to obtain a phase lead at higher frequencies without the phase lag at nearby lower frequencies, and to decrease the gain across a wider frequency range with shallow dips near two frequencies, it was necessary to include an additional BPF in the model (Fig. 4).

The parameters used in the model were fit by eye to the data and are given in Table 1. Rather than manipulating the low- (τ_l) and high- (τ_h) pass filter time constants of each BPF, we found it easier to fit the central frequency (cf) and the band-width (λ) of each BPF. Equations relating these parameters for each BPF are: $\tau_l = 1/(cf \times 10^\lambda \times 2\pi)$ and $\tau_h = 1/(cf \times 10^{-\lambda} \times 2\pi)$.

Curves best fitting the VOR frequency responses following prolonged rotation at 0.01 Hz and habituating components of 0.03 and 0.05 Hz were obtained when the center frequencies of the BPFs were separated by about one order of magnitude (Table 1). One central frequency fell within and the other below the range of the frequency response data. This separation was necessary in order to cancel the phase lag of the higher frequency BPF with the phase lead

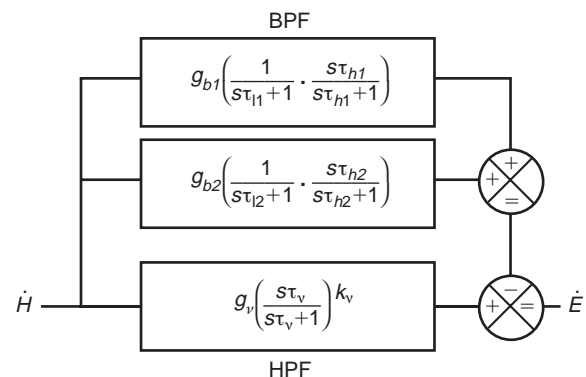

FIG. 4. Linear system model of the VOR that was fit to the VOR frequency response data (Fig. 3). The model converts head velocity (H) to eye velocity (E). It consists of three filters in parallel: a high-pass filter (HPF), which represents the naive VOR frequency response, and two band-pass filters (BPFs). The previously determined values used for the HPF were the time constant ($\tau_v = 10.4$ s) and the order ($k_v = 0.23$). The gain (g_v) was set to the highest median value in each averaged frequency response. The parameters for the two BPFs were independent of each other and were the gain constants (g_{b1}, g_{b2}) and the time constants for the low- (τ_{l1}, τ_{l2}) and high- (τ_{h1}, τ_{h2}) pass filters.

Table 1.

| Habituating component (Hz) | cf ₁ (Hz) | cf ₂ (Hz) | λ ₁ | λ ₂ | g ₁ | g ₂ | τ ₁₁ (s) | τ _{h1} (s) | τ ₁₂ (s) | τ _{h2} (s) |
|----------------------------|----------------------|----------------------|----------------|----------------|----------------|----------------|---------------------|---------------------|---------------------|---------------------|
| 0.03 | 0.005 | 0.05 | 0.3 | 0.3 | 0.5 | 0.7 | 15.95 | 63.51 | 1.60 | 6.35 |
| 0.05 | 0.005 | 0.07 | 0.1 | 0.1 | 0.55 | 0.55 | 25.28 | 40.07 | 1.81 | 2.86 |
| 0.1 | 0.006 | 0.006 | 0.1 | 0.1 | 0.15 | 0.15 | 21.07 | 33.39 | 21.07 | 33.39 |
| ≥0.3 | 0.006 | 0.015 | 0.1 | 0.1 | 0.4 | 0.5 | 21.07 | 33.39 | 8.43 | 13.36 |

of the lower frequency BPF. It also produced a broad decrease in gain, with shallow dips near 0.01 Hz and near the frequency of the habituating component. The model could not produce the full decrease in gain observed at low frequencies while simultaneously fitting phase. This is presumably due to additional non-linear decreases in gain that occur at low frequencies [7].

When the habituating component was 0.1 Hz, there was very little change in the frequency response compared with that in naive goldfish. In this case, the frequency response data were fit well when the center frequencies of both BPFs were equal, and both fell below the range of the frequency response data. When the habituating component was ≤0.3 Hz there was a decrease in gain primarily at 0.01 Hz and an increase in phase lead at frequencies below and including 0.1 Hz. In this case, the frequency response data were fit well when the BPF central frequencies were unequal, with one below and the other just inside the low end of the frequency range.

Taken together, these results show that the frequency response of the VOR following prolonged rotation at two separate frequencies can be simulated by a model in which the output of two BPFs is subtracted from the output of a HPF model of the naive VOR. The dual BPF nature of the habituating frequency response is especially apparent when both habituating frequencies are below 0.1 Hz.

Conclusion

We studied habituation of the goldfish VOR following 1 h of rotation, in the dark, at 0.01 Hz in combination with another component up to 1.0 Hz in frequency. We found that the goldfish VOR still habituated at 0.01 Hz regardless of the frequency of the other component. For combinations of low frequencies (both <0.1 Hz), we found VOR fre-

quency response characteristics suggestive of frequency-specific habituation at two separate frequencies. We also found that the VOR at 0.01 Hz could be dishabituated if the other component was switched to a different frequency, either higher or lower.

Our results show that VOR habituation at a low frequency can still become established even when rotation at a low frequency is combined with rotation at a higher frequency. They show that VOR habituation can become selective for two, and perhaps more, separate frequencies simultaneously. Finally, they demonstrate that the habituated state is dependent upon the spectral content of the head rotational input to the VOR.

References

- Wilson V and Melvill Jones G. *Mammalian Vestibular Physiology*. New York: Plenum Press, 1979.
- Fernandez C and Goldberg JM. *J Neurophysiol* **34**, 661–675 (1971).
- Blair S and Gavin M. *Invest Ophthalmol Visual Sci* **18**, 1086–1090 (1979).
- Jäger J and Henn V. *Exp Brain Res* **41**, 108–114 (1981).
- Baloh RW, Henn V and Jäger J. *Am J Otolaryngol* **3**, 235–241 (1982).
- Weissenstein L, Ratnam R and Anastasio TJ. *Behav Brain Res* **75**, 127–137 (1996).
- Dow ER and Anastasio TJ. *J Comput Neurol* in press.
- Singleton GT. *Laryngoscope* **77**, 1579–1620 (1967).
- Waespe W, Cohen B and Raphan T. *Science* **228**, 199–202 (1985).
- Cohen H, Cohen B, Raphan T and Waespe W. *Exp Brain Res* **90**, 526–538 (1992).
- Pastor AM, de la Cruz RR and Baker R. *J Neurophysiol* **72**, 1383–1394 (1994).
- Torte MP, Courjon JH, Flandrin JM *et al.* *Exp Brain Res* **99**, 441–454 (1994).
- Dow ER and Anastasio TJ. *NeuroReport* **7**, 1305–1309 (1996).
- Dow ER and Anastasio TJ. *J Comput Neurol* **5**, 171–190 (1998).
- Schmid R and Jeannerod M. Vestibular habituation: an adaptive process? In: A. Berthoz and G. Melvill-Jones, eds. *Adaptive Mechanisms in Gaze Control*, vol. 1. New York: Elsevier, 1985: 113–122.
- Schairer JO and Bennett MVL. *Brain Res* **373**, 164–176 (1986).
- Pastor AM, de la Cruz RR and Baker R. *J Neurophysiol* **68**, 2003–2015 (1992).
- Ratnam R and Anastasio TJ. *NeuroReport* **6**, 2129–2133 (1995).
- Robinson DA. *IEEE Trans Biomed Eng* **10**, 137–145 (1963).
- Rommel RS. *IEEE Trans Biomed Eng* **31**, 388–390 (1984).
- Dow ER and Anastasio TJ. *NeuroReport* **8**, 2755–2759 (1997).
- Buettner UW, Henn V and Young LR. *Aviat Space Environ Med* **52**, 73–77 (1981).

ACKNOWLEDGEMENTS: The work was supported by grant MH50577 from the National Institutes of Health.

Received 3 March 1999;
accepted 13 April 1999